

銘傳大學 102 年度研究所碩士班招生考試

建築學系碩士班

第一節

「專業英文」試題

(第 1 頁共 1 頁) (限用答案本作答)

可使用計算機 不可使用計算機



1. 選擇：括弧中兩個英文答案，請圈選出一個對的，每題 3 分 (45%)

It was Le Corbusier's Villa Savoye (薩伏瓦別墅) that most succinctly summed up his five (point, points) of architecture, (which, when) he (have, had) been developing throughout the 1920s.

First, Le Corbusier (lift, lifted) the bulk of the structure off the ground (support, supporting) it by *pilotis* – (reinforce, reinforced) concrete stilts. These *pilotis*, in (providing, provide) the structural support for the house, allowed him to elucidate his next two points: a free façade, meaning non-supporting walls that could (designed, be designed) as the architect wished, and (an, a) open floor plan, meaning that the floor space was free to be configured into rooms without concern for supporting (wall walls).

The second floor (of, to) the Villa Savoye (include, includes) long strips of ribbon windows that (allow, allows) unencumbered views of the large surrounding yard, and (which, where) constitute the (forth, fourth) point of his system.

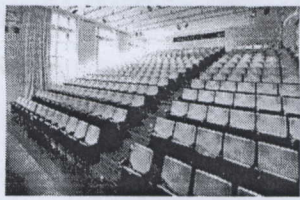
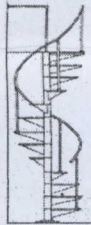
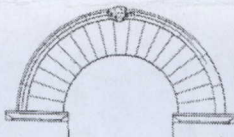
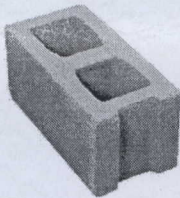
2. 選擇：每張圖片下方的兩個答案，請圈選出一個對的，每題 3 分 (15%)

				
Theater / Exhibition	Scissor stair / Spiral stair	Arch / beam	Brick / Concrete Block	Housing / House

3. 翻譯：英翻中 (25%)

1). I was studying architecture by going to see actual building, and reading books about them. (7%)

2). Le Corbusier (科比意) was an architect, designer, urbanist, writer, and one of the pioneers of what is now called modern architecture. (8%)

3). Koolhaas(庫哈斯) continuously incorporates his observations of the contemporary city within his design activities: the Chinese cities are analyzed according to "performance", a criterion involving variables: density, newness, shape, size, money etc. (10%)

4. 請用英文簡要描述這棟建築 (15%) (Barcelona Pavilion, by Mies van der Rohe)

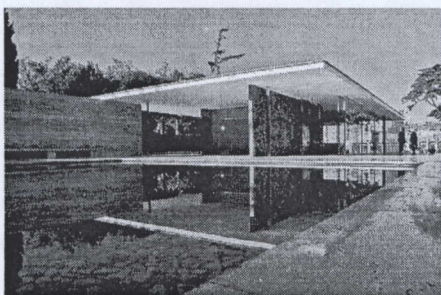

試題完
End of exam